

MULTI-PURPOSE MIRRORS



3 DIRECTIONS

PRODUCT CODE

P.A.S.[®] optics ▶ Code 9090

GUARANTEE



> Unbreakable > light > unalterable > Anti-UV treated
> 5 year guarantee.



TECHNICAL SPECIFICATIONS

- > Lens: PAS optics
- > Dimensions: Ø 910 mm
- > Packaging dimensions: 1020 x 290 x 1030 mm
- > Gross weight: 11.3 kg
- > Angle of convexity: for a field of vision of approximately 180° used at junctions where users are coming from 3 different directions
- > Maximum distance between the mirror and viewer: approx. 10m
- > Fixing kit supplied
- > Full guarantee (mirror, frame and fixings)*
- > Manufactured in France
- > 100% recyclable

FIXING KIT DIAGRAM

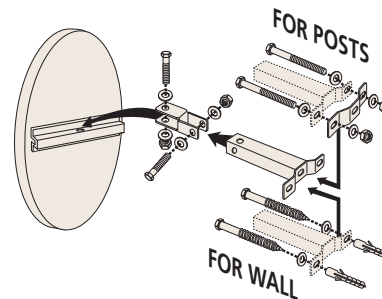

Supplied complete with bolts and brackets kit, adaptable for walls or for posts 60 to 90mm in diameter. Kit is robust, tested to withstand winds of up to 183km/h. Easy to install, allowing precise adjustment of the position of the mirror.

DIMENSIONS

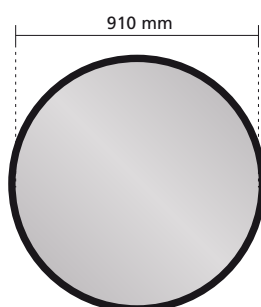

RECOMMENDED INSTALLATION

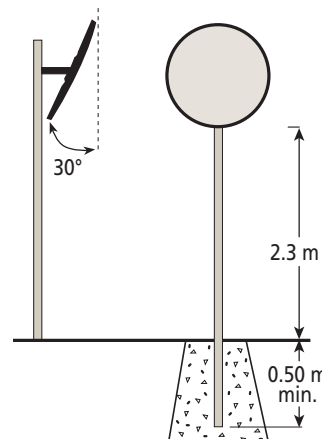

www.vialux.eu

*Under normal operating conditions.